



DUMO

User Manual

Version 1



Table of Contents

1. INTRODUCTION.....	3
1.1. Safety.....	3
1.2. Product overview.....	3
1.3. Operating principle.....	3
2. INSTALLATION.....	4
2.1. Selecting the installation location.....	4
3. WIRING.....	5
4. TECHNICAL SPECIFICATIONS.....	6
6. MAINTENANCE.....	9



1. INTRODUCTION

This manual describes how to install and use SINTROL digital triboelectric ambient dust monitor Dumo.

Sintrol shall not be held liable for any loss or damage whatsoever arising from omissions or errors in this manual or any misuse of the product.

1.1. Safety

Dumo ambient dust monitor is virtually maintenance free. Under no circumstances should the user attempt to replace any components or the PC board. If, for some reason the monitor fails to operate, contact your local distributor or the manufacturer.



It is essential that the unit is correctly grounded! (see section 3.)

1.2. Product overview

Dumo is a dust monitor based on particle charge transfer. It utilises the experience and test data of the same technology Sintrol has developed and perfected over almost two decades. The device has been developed for continuous dust monitoring in industrial environment and it is equipped with three colour LED indicating different dust concentration levels. Dumo is designed for easy installation and operation.

1.3. Operating principle

Dumo measurement principle is based on the charge transfer of solid particles. When solid particles enter into the flow channel, they interact with a sensor rod and affect a small electrical charge. This charge provides a signal which is proportional to the ambient dust level. Schematic diagram of the measurement principle is presented in Figure 1.

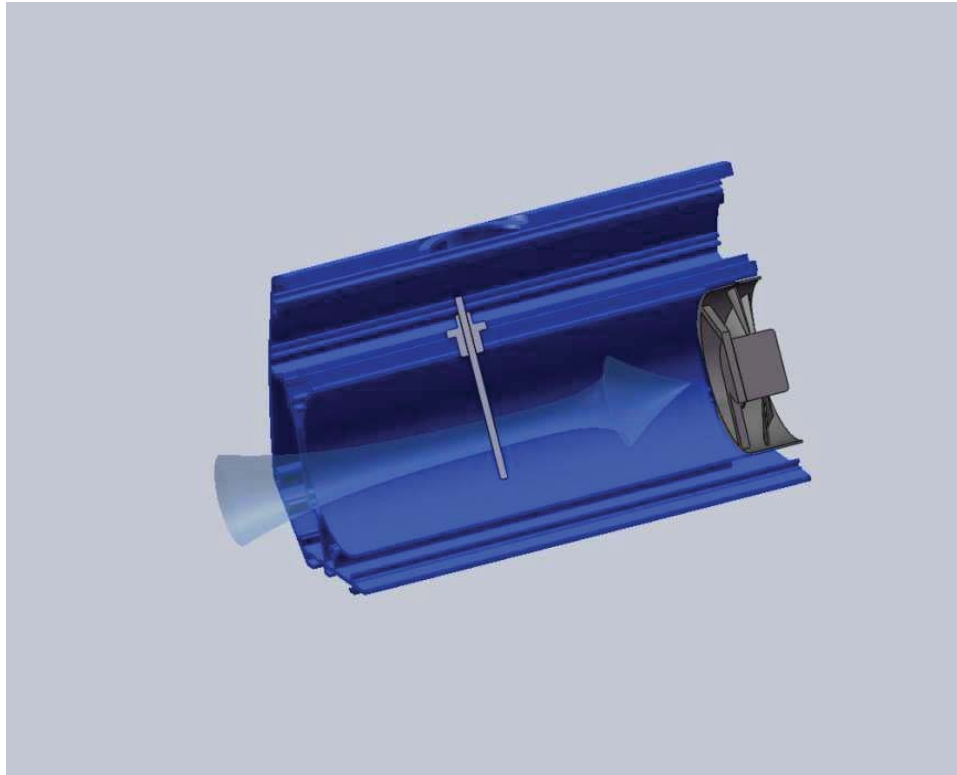

Figure 1. Dumo structure

2. INSTALLATION

2.1. Selecting the installation location

Dumo should be located so that measured data clearly represents dust concentration in a selected work environment. Because of this the user should always think carefully what he wants to monitor and where the device should be placed.

For example Dumo can be placed close to the cement mill if the user is interested in the variation of the amount of dust particles during the process. If the user is interested in dust concentration level in general, then Dumo should be located in a more “peaceful” place, some distance from the process.

There are still certain basic requirements for Dumo monitoring environment which one must take into account when preparing the measurements.

1. Temperature in measurement environment should be between -20 C and +60 C. The more stable temperature, the better.



2. Considerable humidity or condensed water is likely to drastically effect measurement.

3. WIRING

DUMO is connected with following cable:

pink (6)	-	Power input (+) 24 VDC
gray (5)	-	Power input (-) GND
brown (2)	-	RS485 A (+)
white (1)	-	RS485 B (-)
green (3)	-	Auto setup (Button procedure)
yellow (4)	-	4...20 mA
red (8)	-	Relay 2 output
blue (7)	-	Relay 1 output

For Dumo It is extremely important that it is grounded properly. The recommended grounding is presented below where Dumo cable shield is connected to power supply minus (-) button which is grounded properly to the stable ground.

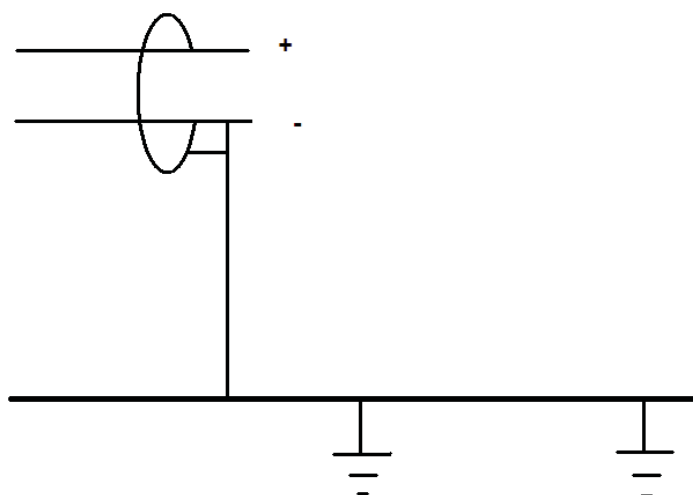



Figure 2. Dumo grounding

Wiring: please note that 24 VDC is the absolute maximum value of voltage used. Because of this, the user should pay attention to possible voltage peaks when using the device. Care must be taken especially when the device is powered from the power supply in an industrial environment.

4. TECHNICAL SPECIFICATIONS

Measurement objects	Solid particles in ambient air
Particle size	0.3 µm or larger
Measurement principle	AC signal (charge transfer)
Averaging time	1 – 1 h 30 min
Output signals	2 solid state relays Isolated 4-20 mA Serial communication
Ambient temperature	-20...+60 °C
Enclosure / casing	Aluminium, Stainless steel
Power supply	24 VDC
Cable connection	5 meter cable
Weight	About 3 kg

5. OPERATION

Dumo measures solid particles in ambient air. The device has “Alert” and “Alarm” levels which correspond to certain dust concentration levels above the “Normal”. These three levels are indicated by Red, Yellow and Green colours of indicator led in front cover.

Green

Normal level

Yellow

Alert level



Red

Alarm level

When the device is switched ON, it starts to measure with the following regular settings: regular Alert and Alarm levels are based on measurements carried out in Sintrol test laboratory. Due to this, it is recommended that the user does a new setup either manually or using auto-setup procedure. Manual setup is done by setting new suitable values to the L1 and L2 functions. Auto-setup procedure starts automatically when button wire (green) is connected to the power supply minus (-) button. Both functions (and other detailed information about setting and changing measurement parameters can be found in the software manual.

Factory default for alarm levels:

Normal level	1000 - 2000 units in clean office air
Alert level	1 000 000
Alarm level	4 000 000

In normal indoor environment Dumo signal level should stay under 5000 at the most of time.

Ambient monitoring and ambient dust concentration level is always strongly depending of measurement environment. Because of this it is strongly recommended that user set alarm levels always in new measurement location or environment

In practise there are three ways to do dust monitoring with Dumo:

- The simplest way is to monitor concentration level by using indicator LEDs. In this type of monitoring, only power supply is needed.
- The second way is to do monitoring with RS485-terminal. When using RS485 terminal, it is possible to monitor data on-line on a PC screen. In this



case, the user needs power supply, USB to RS485/422 converter and PC with terminal software, like Hyperterminal, which is shipped with Windows. Detailed information and description of software commands can be found in Dumo Software Manual. Monitoring with using RS485/422 converter and PC is definitely the most recommended way of monitoring. When using this option it is possible to change alarm levels and averaging time for example.

- The third possibility is to monitor data on-line using the mA output supplied with a remote display. When using this option the mA screen is needed.

Connections for different types of monitoring are presented in Figure 3.

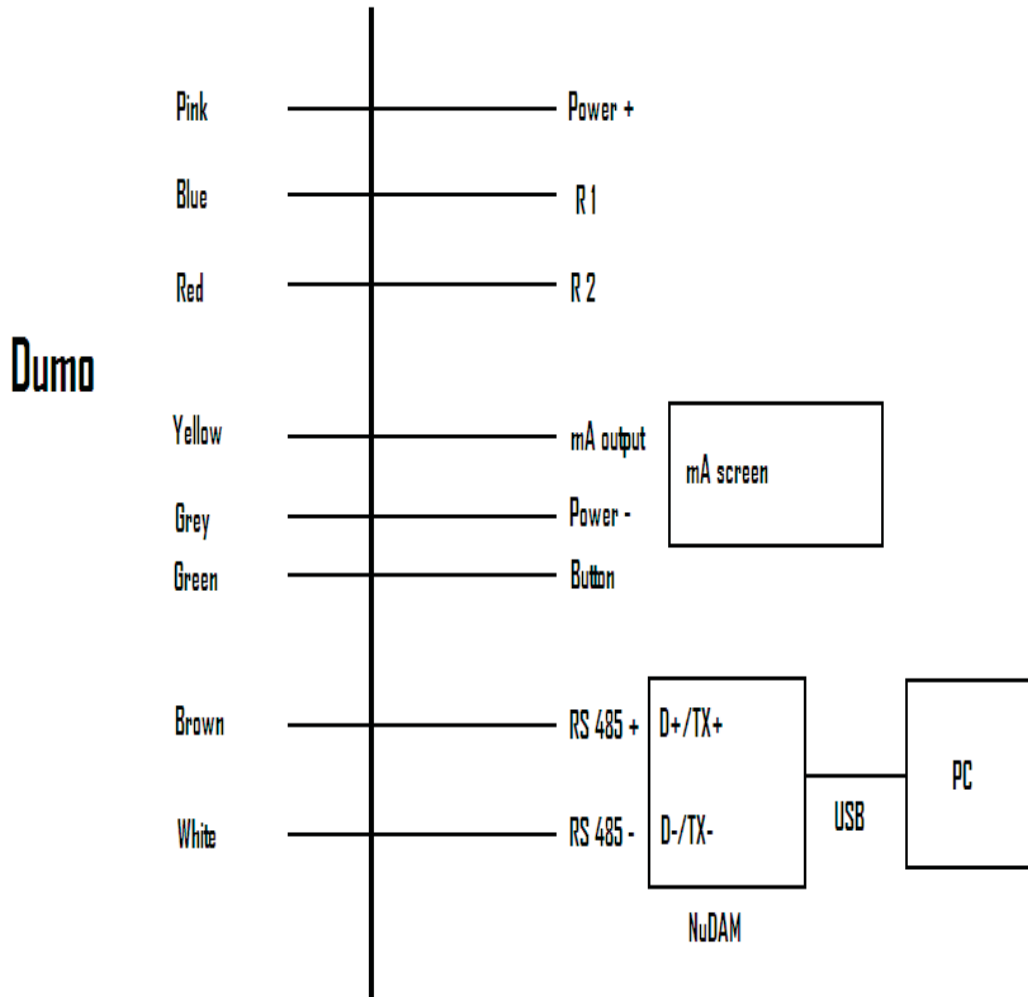

Figure 3. Dumo connection possibilities

6. MAINTENANCE

Dumo is designed so that only a very little maintenance is needed. However, the user should clean the measurement channel after some period of time. The cleaning period varies, depending on monitoring conditions and dust concentrations. The user should check the channel frequently.